

Picture hanger Safety Hook Series



ULTIMA

Picture hanger Safety Hook Series



- With its compact mechanism and high strength, it is applied in fields where safety is required, such as picture hangers.
- Simple one-touch position adjustment for hanging paintings, frames, and panels.
- One-touch locking and adjusting function.
- Locked by simply inserting the wire and unlocked by operating the pin, taking advantage of its impact-resistant structure.
- Easy to operate for smooth level movement.

Wire	φ1.2、φ1.5
Allowable load value	Within 40 kg to 65 kg * Allowable load values vary depending on the wire diameter * Allowable load values are based on a safety factor of approximately 1/3 of the maximum static load value.
Main applications	Special fittings for hanging art works such as paintings, frames, panels, etc.
Main customers	Art galleries, museums, libraries, art galleries, public facilities, DIY, and many others



What is the difference between the safety hook series and general hanger hooks?

Picture hangers are mainly used to hang frames and panels. Manufacturers all over the world are selling the design (and cost, of course...), and they are used mainly in museums. The differentiation of picture hanger itself is directly focused on the design.

The biggest difference between our picture hanger safety hook series and general hanger hooks is that our picture hanger safety hook series has a thinner wire diameter, which allows you to hang heavy objects safely.

The reason is that the gripping mechanism of the hanger hook is different from that of general hanger hooks.

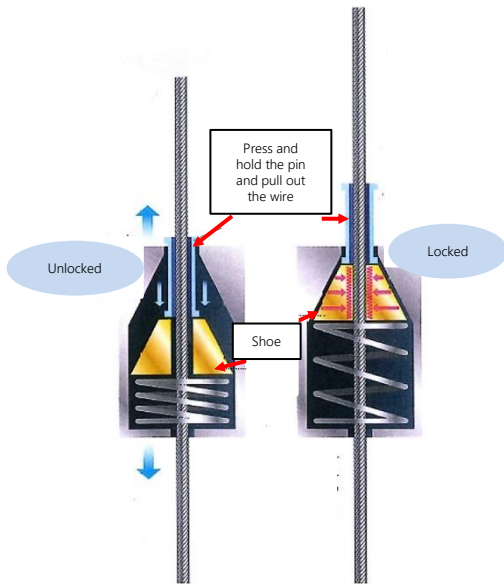

ULTIMA grip : Shoe type grip

Shoe type grips (surface fixation) distribute the load by clamping the wire between two surfaces, thereby reducing the load on the wire. The original strength of the wire is maintained.

The shoe-type grip is a proprietary technology of Ultima.

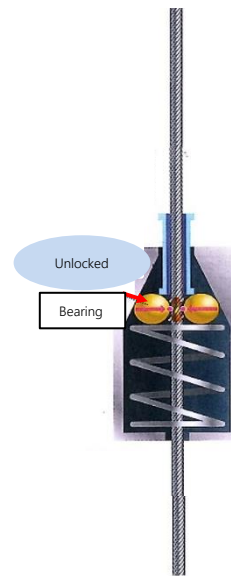

Other grip : Bearing type grip

Bearing type grips (point fixation) have less braking force because the force is concentrated at a single point, and the wire is easily damaged. The wire is easily damaged.

Safety	○	<ul style="list-style-type: none"> High strength and high safety ratio Utilized in industrial products 	△	<ul style="list-style-type: none"> Often utilized in display and interior design
Strength	○	<ul style="list-style-type: none"> Surface contact <u>Strong grip, especially resistant to vibration *1</u> 	×	<ul style="list-style-type: none"> Point contact Grip strength is low. Weak against shock and vibration *2
Release	×	<ul style="list-style-type: none"> Grip force is strong. Difficult to release by hand (finger) *3 	○	<ul style="list-style-type: none"> Grip force is low Easy to release by hand (finger)
Burden on wire	○	<ul style="list-style-type: none"> Surface fixation <u>Less burden due to distributed load</u> Less damage and indentation such as strand breakage and waviness 	×	<ul style="list-style-type: none"> Point fixation Load is concentrated, so there is a heavy burden. Damage and indentation such as strand breakage and waviness are inevitable. Wire maintenance is necessary
Production	○	<ul style="list-style-type: none"> <u>Original design, not an off-the-shelf product</u> <u>Other companies cannot easily manufacture (difficult to manufacture equivalent products)</u> 	×	<ul style="list-style-type: none"> Uses off-the-shelf bearings Easy to manufacture

*1 : 90% to 100% of JIS standard wire breaking load of 170kg based on SUS304p1.5mm (7*7) wire test values.

*2 : 50-70% of 170kg of JIS standard wire breaking load based on SUS304p1.5mm (7*7) wire test value.

*3 : Hybrid mechanism (pat.p) is also available to solve the disadvantage of difficulty in releasing the gripping force.

Basic grip operation

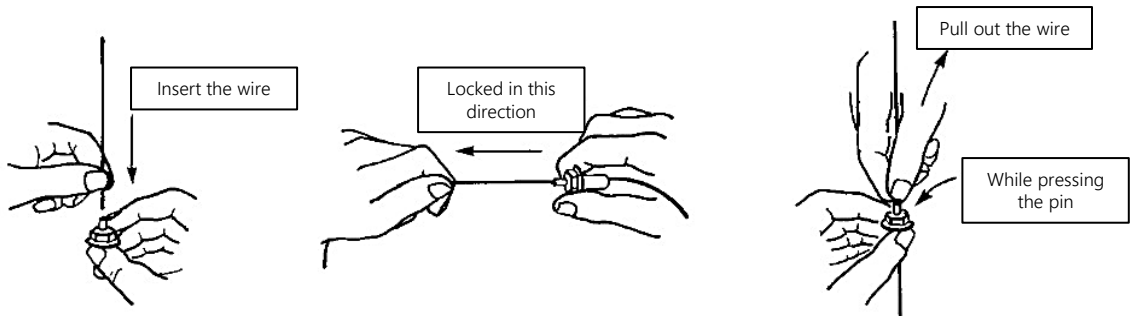

Grip strength

Wire	Maximum Static Load Value	Allowable Load Value
Φ1.5	1670N~1880N (170kg~192kg)	490N~640N (50kg~65kg or less)

* The maximum static load value is the maximum value when a stainless wire (7 x 7) is used for the grip in a stationary state and pulled until the wire breaks (when it breaks).

* The allowable load is calculated with a safety factor of approximately 1/3 of the maximum static load value, but the safety factor should be considered depending on the conditions of use.

* The maximum static load value varies depending on the type of wire used. Please contact us if you have any questions.

Comparison of allowable load value by wire diameter

Wire	ULTIMA grip : Shoe type grip	Other grip : Bearing type grip
Φ1.5 *1	50kg ~ 65kg	30kg

* The allowable load is calculated with a safety factor of approximately 1/3 of the maximum static load value, but the safety factor should be considered depending on the operating conditions.

* 1 Allowable load differs depending on the type of hanger hook.

For general grips, the wire diameter equivalent to an allowable load of 65 kg is φ2.5.

In contrast, Ultima grips can be used with φ1.5 wire diameters, which is most commonly used for hanging exhibits.

In fact, the grips themselves are often hidden behind the frames, so it is the wire diameter that really stands out.

With thinner wire, heavy objects can be hung strongly, beautifully, and safely in a compact body.

This is the Picture Hanger Safety Hook series.

Important : About fixing screws to the wall

Screws for fixing to the wall are not included because the type of screw used depends on the material and structure of the mounting surface.

In order to select the appropriate screws for the material of the wall, we will introduce how to select screws for each material.

Check wall material and structure

1. Check it out by looking at it



Gypsum board with cross-lined



Wooden wall

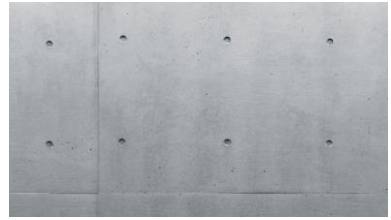

Concrete wall

2. Try pricking the wall with a thin needle

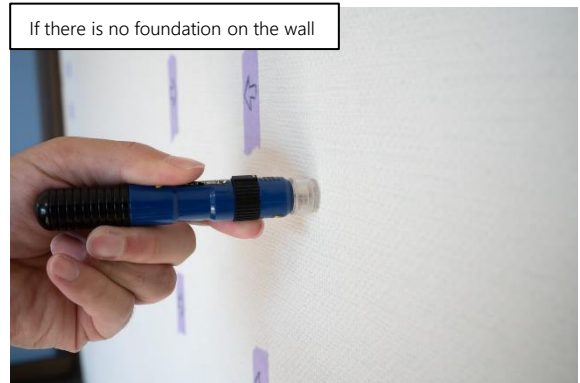
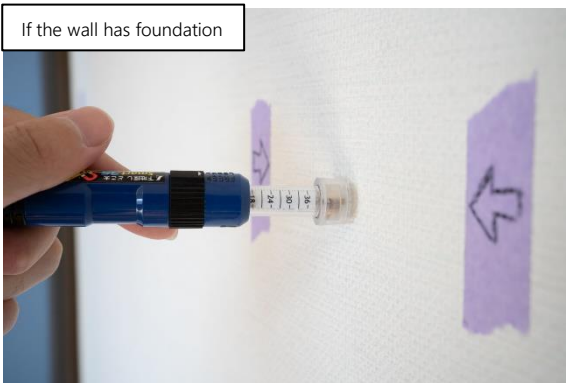

Stick a thin needle into an inconspicuous place on the wall. * Use a substrate sensor (needle type).

If there is a substrate, the needle sticks and stops in the middle (about 15 to 25 mm).

In this case, it is often the case that the concrete or wooden wall is covered with cloth.

Also, if you look at the tip and see white powder on it, the wall is a plasterboard wall; if no powder is on it, the wallpaper is probably on a wood wall.

If there is no substrate, the needle will go all the way in. It is very easy to tell.

Reference : How to choose the right screw for the material of the wall

Generally, screws used for fixing to the wall should be 4 to 5 cm long.

However, please note that the load capacity will vary depending on the material of the mounting surface and the condition of the substrate.

For example, plasterboard walls attached with picture hangers or interior anchors have a lower load-bearing capacity than wood or concrete walls.

Select screws that are thinner than the diameter of the holes in the attached wall anchors and screw heads that are larger than the diameter of the holes in the anchors.



Plasterboard

Screw type: Varies depending on the substrate

Gypsum is the main ingredient of this material, which is commonly used in Japanese houses and condominiums.

The wall is hollow except for the back side where the substrate is inserted.

The gypsum board on the surface is easily crumbled and screws do not work, so it is necessary to put screws at the location where the substrate is placed.

The base material can be wood, metal, or concrete.

When placing screws, use screws or plugs that are appropriate for the substrate material.



Wooden wall (with gypsum board substrate)

Screw type: wood screw

Wood screws can be used to drive directly into thick wood walls or when the base of the plasterboard is wood.

In most cases, there is no need to drill holes or use plugs. However, if the thickness is less than 11 mm, fix the wall to the base material at the back of the wall in the same way as when fixing to plasterboard.



Concrete wall (with gypsum board substrate)

Screw type: Anchor plug for concrete

Concrete is a material that tends to deform easily, making it difficult for screws to work.

Therefore, a plastic or nylon concrete anchor plug is required.

The plug expands to fill the gap and hold the anchor firmly in place.



Metal (for plasterboard base: light steel frame)



Screw type: Tapping screw











If the plasterboard base is metal, such as LGS (lightweight steel frame), use tapping screws that are threaded all the way to the neck.

Use a drill to make a pre-drilled hole with a smaller diameter than that of the screw, and use an electric screwdriver to tighten the screw.

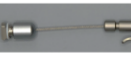

Product List

Picture Hanger Safety Hook Series Wire set

① Rail	② Mounting point	③ Allowable load
 <p>UJA-PR S (silver)</p>	Wall-mounted rail	65kg
		A
		50kg
		B
	Ceiling-mounted rail	40kg
		C
		2kg
		D
 <p>UJA-PR B (bronze)</p>	Ceiling-mounted rail	65kg
		E
		50kg
		F
	Wall-mounted rail	40kg
		G
		2kg
		F
Other manufacturer's rail *Hook fitting for loop wire is required	Wall-mounted rail	65kg
		I
		50kg
		J
	Ceiling-mounted rail	40kg
		K
		65kg
		I
	Ceiling-mounted rail	50kg
		J
		40kg
		K

A: UGS-F		B: U-150F		C: 1540-F		D: UJA-PFF	
E: UGS-RA		F: U-150RA		G: 1540-RA		H: UJA-PFRA	
I: UGS-1		J: U-150		K: 1540-BS			

Product Specifications (① rail)

	rail UIA-PR S	rail UIA-PR B	End caps (both ends)
			
Color	Silver	Bronze	Black
Material	Aluminum extrusion molding		natural rubber
Size	L=900mm×2sets × D10mm × H23mm		-

* Because the substrate is different, rail mounting screws are not included. Please select screws that match the wall material.

Recommended: $\varnothing 3.5$ to $\varnothing 4.0$, length 30 mm or more

* Drilling holes in the rail is not included because of the difference in the substrate location. Please check the substrate position before drilling.

Recommended: 4.5mm to 5.0mm holes should be drilled using an electric drill, etc.

* Rails are made of aluminum. When cutting the length, it is possible to cut with a hacksaw.

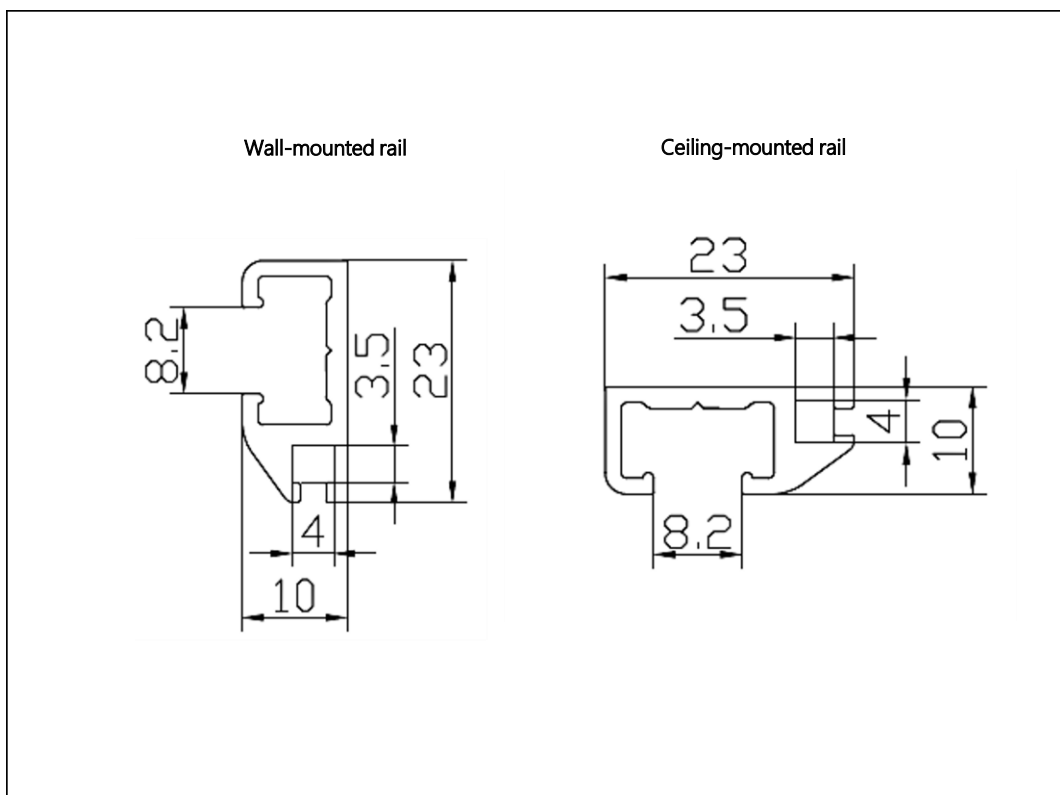

Product Specifications (② wall-mounted rail)

A : UGS-F	B : U-150F	C : 1540-F
-----------	------------	------------

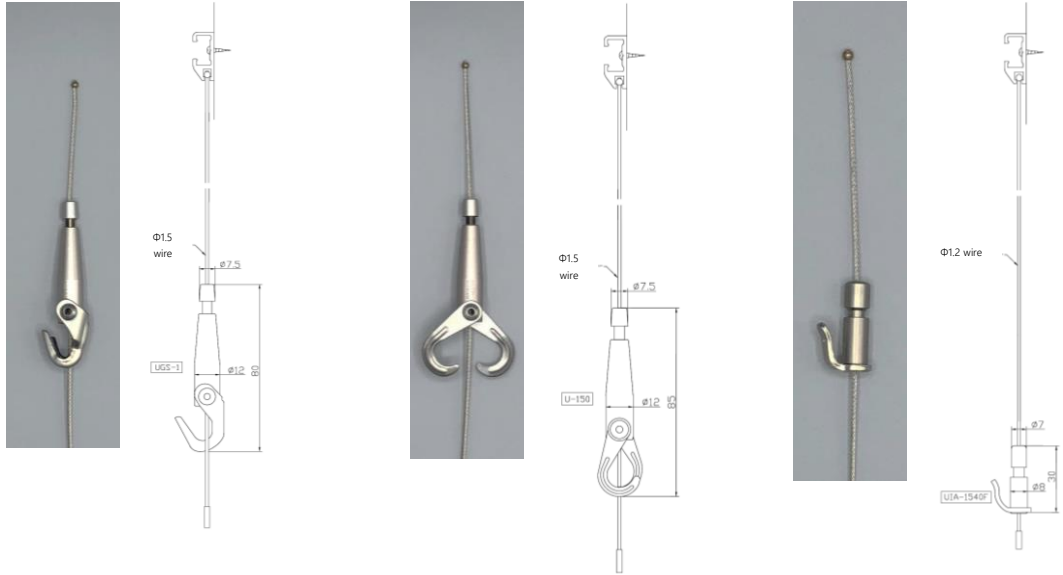

Wire	Φ1.5mm SUS304 (7×7)		Φ1.2mm SUS304 (7×7)
Wire length	L=1,000mm, 1,500mm		
Material	Body : Aluminum, Hook : Stainless steel		Body : Brass, Hook : Brass, Steel
Finishing	Anodized aluminum		
Allowable load	<u>640N (65kg)</u>	<u>490N (50kg)</u>	<u>390N (40kg)</u>
Note	<u>Only for our rail UIA-PR</u>		

* Use within the working load.

* (Loop type) Please attach the hook at the hanging point firmly so that it can withstand the working load.

* Do not use a wire that is broken or damaged.

* Make sure that the metal fittings are locked before hanging a frame or other hanging object.

* Please make sure that the level is in a state where the hanging object is supported and no load is applied to it.

* Avoid using the product outdoors, in high temperature, high humidity, shock, or in a state of constant vibration.

* Do not use any wire other than the wire provided with the set.

* Do not apply paint to hangers, wires, etc.

* Not suitable for any other purpose other than general use of hangers.

†L=1,000mm and 1,500mm are standard wire lengths, but other lengths are also available by special order.

* For improvement, the shape and specifications are subject to change without notice.

Product Specifications (② ceiling-mounted rail)

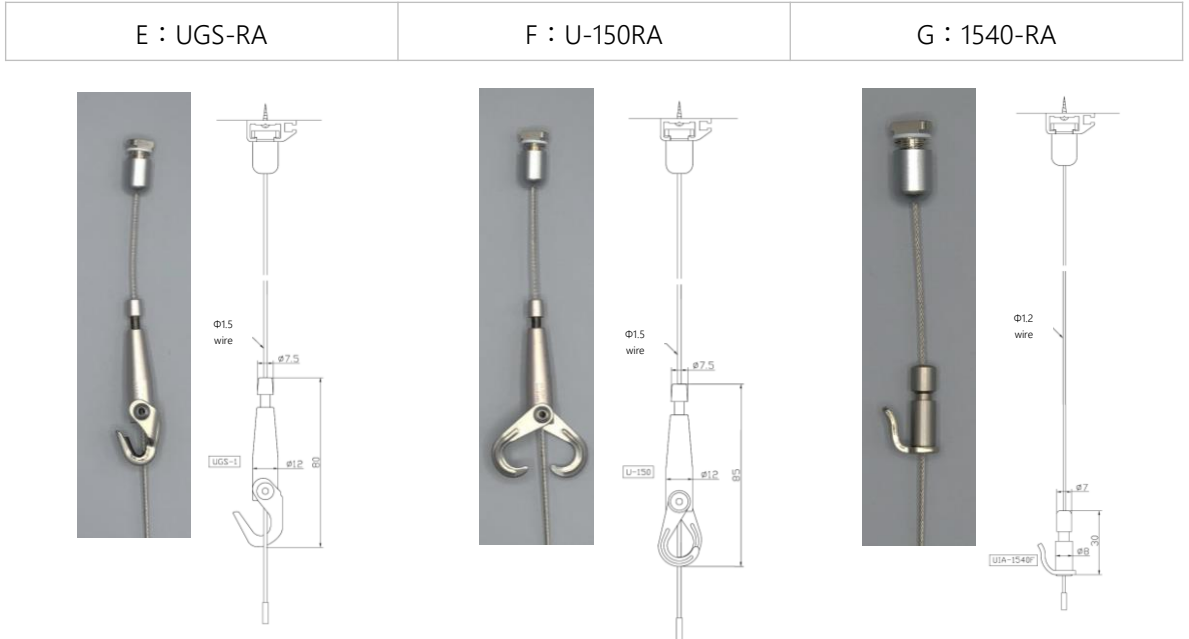

Wire	Φ1.5mm SUS304 (7×7)	Φ1.2mm SUS304 (7×7)
Wire length	L=1,000mm、1,500mm	
Material	Body : Aluminum、Hook : Stainless steel	Body : Brass、Hook : Brass、Steel
Finishing	Anodized aluminum	
Allowable load	<u>640N (65kg)</u>	<u>490N (50kg)</u>
Note	<u>Only for our rail UIA-PR</u>	

- * Use within the working load.
- * (Loop type) Please attach the hook at the hanging point firmly so that it can withstand the working load.
- * Do not use a wire that is broken or damaged.
- * Make sure that the metal fittings are locked before hanging a frame or other hanging object.
- * Please make sure that the level is in a state where the hanging object is supported and no load is applied to it.
- * Avoid using the product outdoors, in high temperature, high humidity, shock, or in a state of constant vibration.
- * Do not use any wire other than the wire provided with the set.
- * Do not apply paint to hangers, wires, etc.
- * Not suitable for any other purpose other than general use of hangers.
- * L=1,000mm and 1,500mm are standard wire lengths, but other lengths are also available by special order.
- * For improvement, the shape and specifications are subject to change without notice.

Product Specifications (② other manufacture's rail)

I : UGS-1	J : U-150	K : 1540-BS
-----------	-----------	-------------

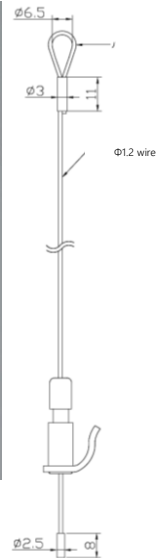
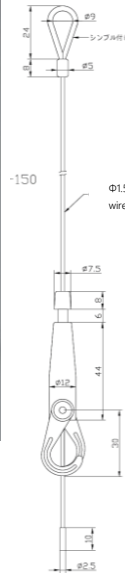
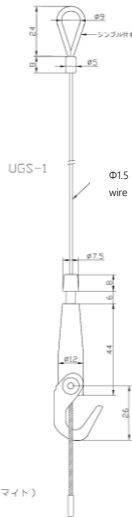

Wire	Φ1.5mm SUS304 (7×7)		Φ1.2mm SUS304 (7×7)
Wire length	L=1,000mm、1,500mm		
Material	Body : Aluminum、Hook : Stainless steel		Body : Brass、Hook : Brass、Steel
Finishing	Anodized aluminum		
Allowable load	<u>640N (65kg)</u>	<u>490N (50kg)</u>	<u>390N (40kg)</u>
Note	<p style="text-align: center;"><u>For hook type metal fitting installation</u> <u>* Please select when using rails other than our UJA-PR rail.</u></p>		

* Use within the working load.

* (Loop type) Please attach the hook at the hanging point firmly so that it can withstand the working load.

* Do not use a wire that is broken or damaged.

* Make sure that the metal fittings are locked before hanging a frame or other hanging object.

* Please make sure that the level is in a state where the hanging object is supported and no load is applied to it.

* Avoid using the product outdoors, in high temperature, high humidity, shock, or in a state of constant vibration.

* Do not use any wire other than the wire provided with the set.

* Do not apply paint to hangers, wires, etc.

* Not suitable for any other purpose other than general use of hangers.

※L=1,000mm and 1,500mm are standard wire lengths, but other lengths are also available by special order.

* For improvement, the shape and specifications are subject to change without notice.

Work Instruction (rail)

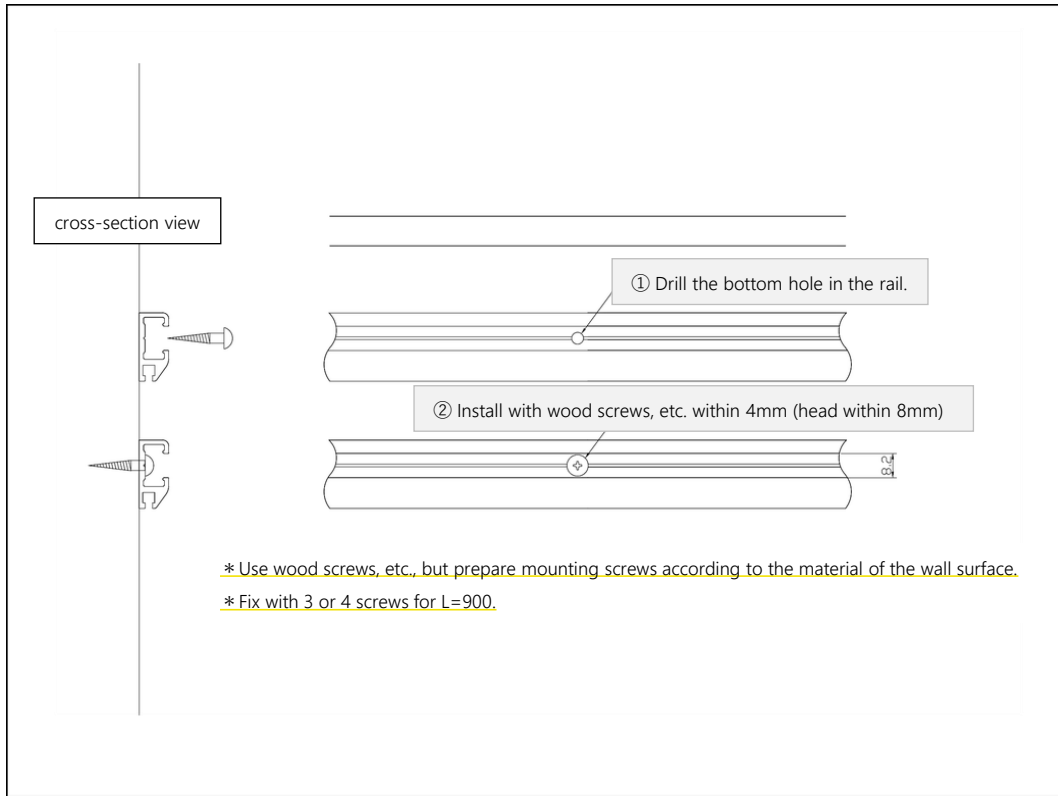

Work Instruction (rail joint)

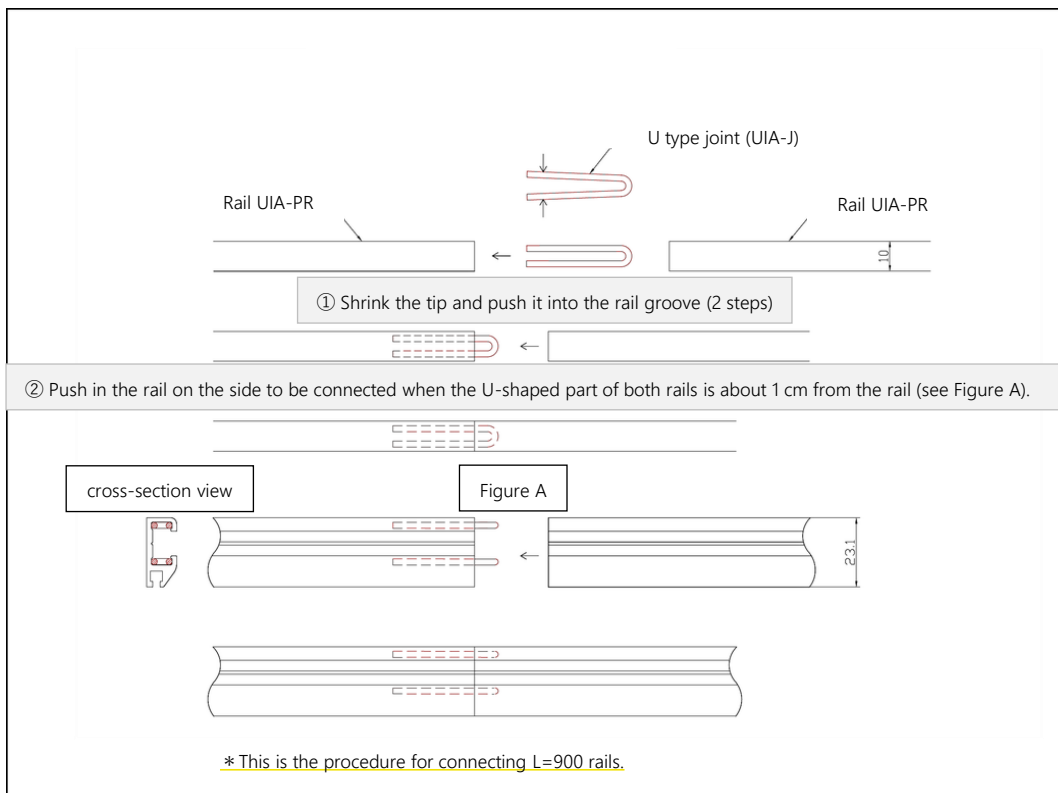

Work Instruction (wall-mounted rail + picture hanger)

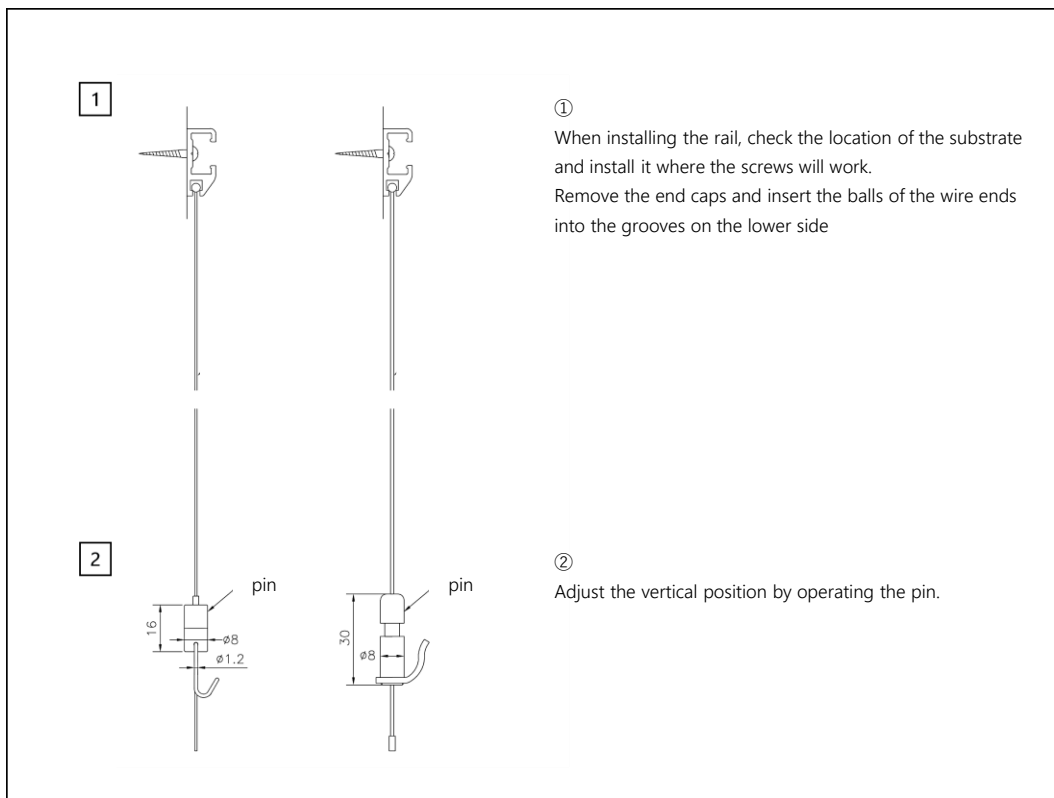

Work Instruction (ceiling-mounted rail + picture hanger)

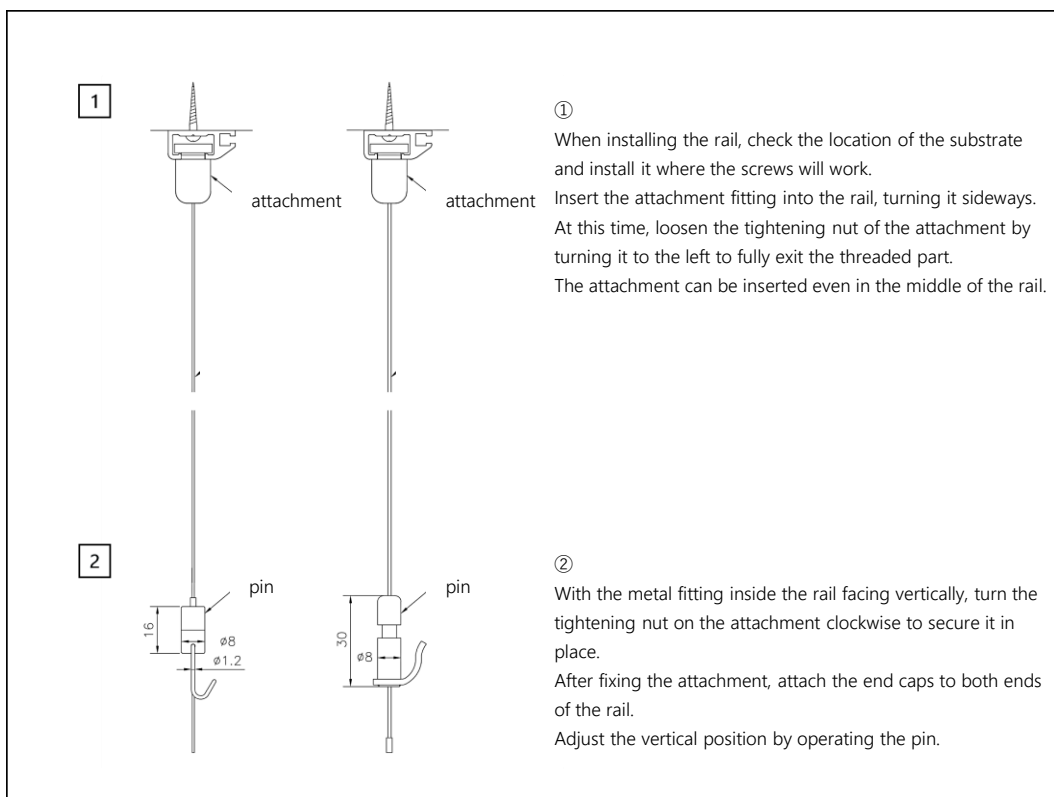

Attention

- Rail mounting screws are not included because the substrate is different. Please select screws that match the wall material.
Recommended: \varnothing 3.5 to \varnothing 4.0, length 30 mm or more
- Since the substrate position is different, we do not drill holes in the rails. Please check the substrate position before drilling.
Recommendation: Drill holes of 4.5mm to 5.0mm with an electric drill, etc.
- Screws for rail installation are usually recommended to be set @450mm for L=900.
- When installing the rail, check the location of the substrate and be sure to install the rail in a location where the screws are secure.
- Please note that the strength of the screws will affect the safety strength of the rail.
- Special metal fittings may be required depending on the mounting location.
- Do not apply paint or oil to the grips or wires.
- Mounting method varies depending on the wall material.
- We assume no responsibility for any damage or accident caused by incorrect installation.

FAQ

Q1. What wire diameters are available?

We have two types of wire diameters, φ 1.5mm and φ 1.2mm.

Please select the one that best suits your application.

Q2. What is the allowable load of hanger hooks?

U-150 series can hold up to 50 kg, UGS series can hold up to 65 kg, and 1540 series (coated wire) can hold up to 10 kg.

The allowable load value is set at a safety factor of approximately 1/3 of the maximum static load value.

Q3. Can the wire length dimension be changed?

Yes, it can be custom-made.

The standard length is L=1,000mm or 1,500mm, but longer lengths are also available.

Please contact us for the delivery date and price.

Q4. Can the number of hanger hooks be increased?

Yes, we can make custom-made products.

Multiple hangers can be set on one wire.

Please contact us for the delivery date and price.

ULG ULTIMA Co.,Ltd.
Ultima Line Grip